

# Helwig Carbon Bearing Protector Kit BPK-4 & BPK-AM Brush Holder Installation Instructions



ISO 9001 Certified

Helwig's BPK-4 and BPK-AM Bearing Protection Kits are UL Recognized Components for both U.S. and Canada

Helwig Carbon Products, Inc. Bearing Protector Kits are designed to be installed using two threaded bolts (Option 1) or 3M™ Dual Lock™ (Option 2).

We recommend the brush ride perpendicular to the shaft. The track in which the brush rides on the shaft should be free of scratches, nicks, dents or defects of any kind. Ideally the shaft surface should be clean with a surface finish between 32 and 63 RMS. Do not use any external lubrication. The brush will supply its own lubrication.

## Option 1

The BPK-4 uses two 10-32 UNF threaded bolts and the BPK-AM uses two 5 mm bolts (M5x0.8). The holders should be mounted 0.090" to 0.125" (2.3 mm to 3.2 mm) from the shaft. Mounting dimensions are given in the diagram below.

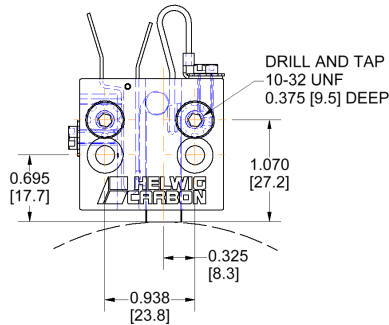

**0.375 X 0.250  
4 Hole  
PT#: BPK-4**

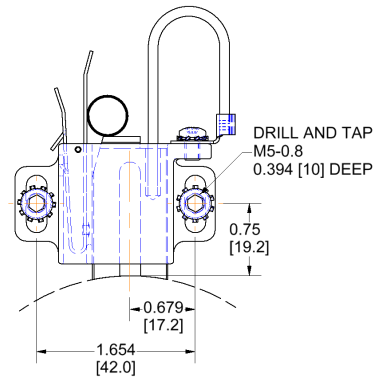

**0.787 X 0.394  
(20 mm X 10 mm)  
PT#: BPK-AM**

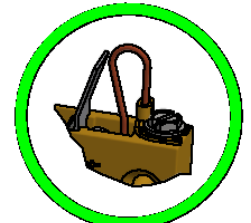

CORRECT TERMINAL INSTALLATION



INCORRECT TERMINAL INSTALLATION

**Unlock** spring assembly, **install** brush making sure the brush is inserted properly in the brush holder and the brush terminal is securely fastened to the brush holder. **Replace** spring assembly into holder making sure it is **locked** into place.

## Option 2

**Caution:** When mounting Helwig Carbon Products, Inc. Bearing Protector Kits using Dual Lock **make sure the separate ground wire, which is supplied with kit, is secured to ground.** Avoid painted surfaces while securing ground connection. The 3M™ Dual Lock™ supplied with the holders will not conduct current.

1. **Remove** liner from adhesive and place 3M™ Dual Lock™ onto **Brush Holder**
  - a. See page 2 for recommendations for pressure sensitive adhesive

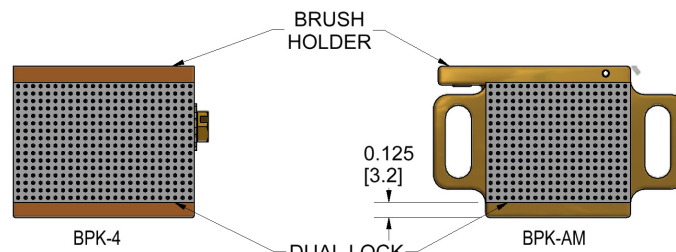

# Helwig Carbon Bearing Protector Kit BPK-4 & BPK-AM



## Brush Holder Installation Instructions

ISO 9001 Certified

2. **Position** the brush holder so that the brush is perpendicular to the shaft and the bottom of the brush holder is 0.090" to 0.125" (2.3 mm to 3.2 mm) from the shaft.
3. **Mark** the position of the 3M™ Dual Lock™ on the unit

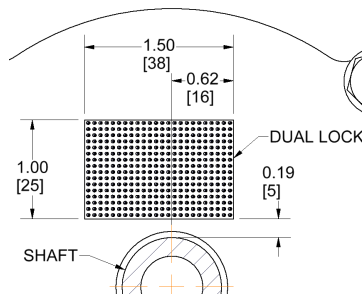

4. **Remove** liner from adhesive and place 3M™ Dual Lock™ onto unit
5. **Push holder** onto unit. Make sure 3M™ Dual Lock™ is securely fastened.
6. **Connect** one end of the supplied ground wire to the brush holder and the other end to ground.
7. **Unlock** spring assembly, **install** brush making sure the brush is inserted properly in the brush holder and the brush terminal is securely fastened to the brush holder. **Replace** spring assembly into holder making sure it is **locked** into place.

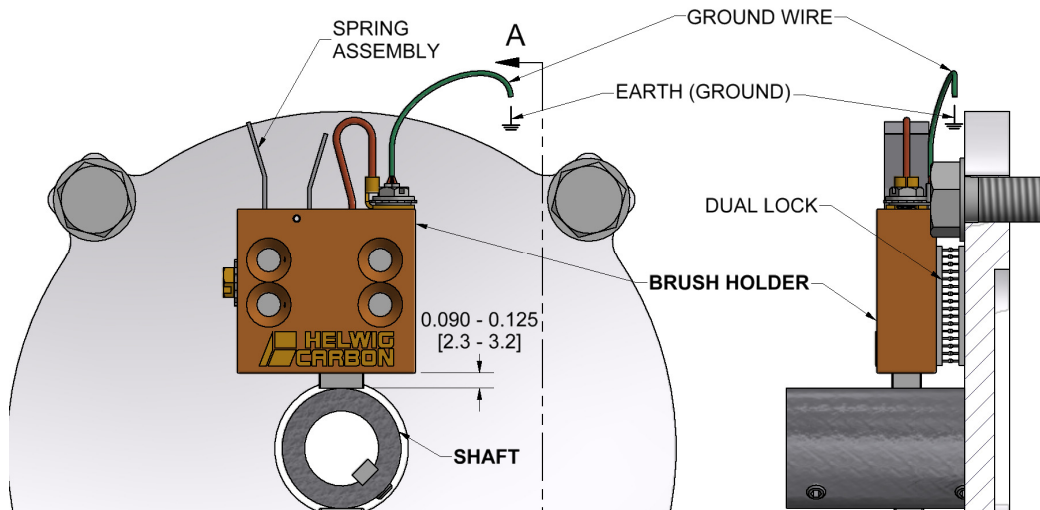

### 3M™ Dual Lock™ Pressure Sensitive Adhesive attachment:

The fasteners and substrate surfaces should have equilibrated for a minimum of 1 hour at temperatures of 68F (20C) or greater before application. Generally these adhesive backed fasteners should be applied to surfaces that are smooth, dry and free of oils, mold, release agents or other surface contaminants.1

The substrate surface should be cleaned to remove any surface contaminants with an appropriate cleaning method for the customer's substrate, type and quantity of surface contaminants that need to be removed. Note: Be sure to follow all government regulations and the manufacturer's precautions and directions for use when using solvents or other cleaning methods.

After the substrate has been cleaned and dried, the liner is removed from the fastener's adhesive and without touching the adhesive, the fastener's adhesive is applied to the surface using light finger pressure. The fastener can then be rolled down, to increase contact of the adhesive with the substrate's surface. Extra care must be exercised when rolling down 3M™ Dual Lock™ Reclosable Fasteners to prevent bending of the stems which can compromise the closure strength.

Adhesive bond strength increases with time, pressure and temperature. A minimum of one hour dwell is recommended before applying a load or disengaging assembled parts. Recommended time to achieve maximum bond strength is 24 hours.

For more information go to 3M's website for [Dual Lock™](#)