

Helwig Carbon Bearing Protector Kit

BPK-S (Patent Pending)

Brush Holder Installation Instructions



We recommend the brush ride perpendicular to the shaft. The track in which the brush rides on the shaft should be free of scratches, nicks, dents or defects of any kind. Ideally the shaft surface should be clean with a surface finish between 32 and 63 RMS. Do not use any external lubrication. The brush will supply its own lubrication.

The BPK-S uses two 10-32 socket head cap screws. The holders should be mounted 0.090" to 0.125" (2.3 mm to 3.2 mm) from the shaft. Mounting dimensions are given in the diagram below. The brush retainer clip can be used as a guide for proper spacing above the shaft.

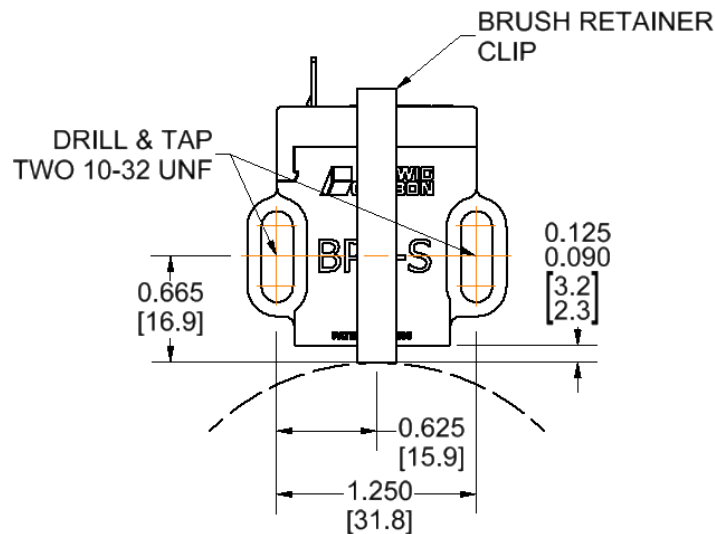

Once the holder is installed **remove** the clip used to hold the brush in place. **Connect** one end of the supplied ground wire to the brush holder and the other end to ground.