

Helwig Carbon Bearing Protector Kit BPK-IM2

Brush Holder Installation Instructions



ISO 9001 Certified

We recommend the brush ride perpendicular to the shaft. The track in which the brush rides on the shaft should be free of scratches, nicks, dents or defects of any kind. Ideally the shaft surface should be clean with a surface finish within the standard range of most motor manufacturers of 8 to 63 RMS. Do not use any external lubrication. The brush grade has the optimal lubrication needed.



The BPK-IM2 Bearing Protector Kit is mounted using two 4-40 or 3 mm screws. The holder should be mounted 0.090" to 0.125" (2.3 mm to 3.2 mm) from the shaft.

1. **Drill and tap** two 4-40 UNF or M3 holes 0.375" (9.5 mm) deep per diagram below.

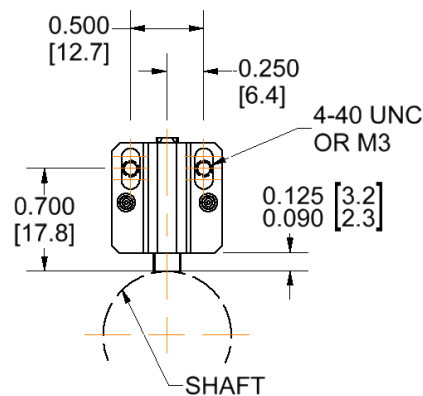

2. **Attach** holder to unit using two 4-40 or M3 screws

