



NEWSLETTER

INNOVATION

Helwig Carbon Products’ influence in the carbon brush industry over the decades

The technical product innovations developed by Helwig Carbon Products have received universal acceptance over many decades, have been copied by carbon brush manufacturers world-wide, and are still in use today.

Sliding electrical contacts were originally made of all metal, most often copper. Some designs consisted of bundles of bristles which led to the contact being called a “brush”. Early in the development of rotating electrical machines the abrasion of particles from the metal on metal sliding contact soon was considered unacceptable.

The invention of the carbon brush as a sliding electrical contact was somewhat controversial with Charles J. Van DePoele first applying carbon brushes on an electric transit car and George Forbes being credited

with the patent on the carbon brush in 1885. There is no question, however, that the development of carbon brushes was key to the future of electrical machines as the primary drive system of the 20th century.

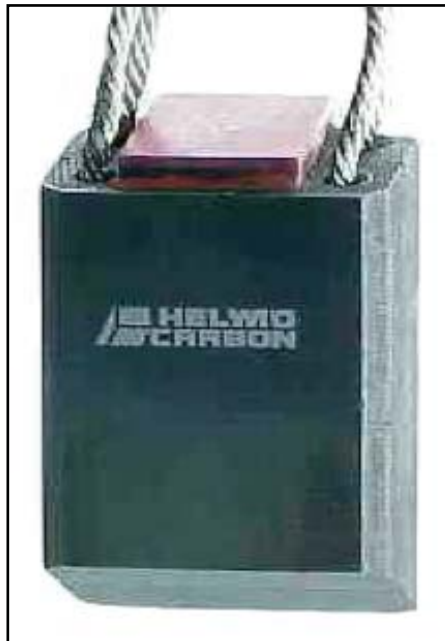

Transert

Early in the history of Helwig Carbon there was experimentation on the use of multiple grades in a single brush. It was determined that the range for good performance could be widened by adding another material to the standard brush for more filming or more cleaning action.

The transert brush was patented by Helwig Carbon and Walter O. Helwig in 1936 under U.S. Patent 2,105,038. This design incorporated a wedge shaped insert of a different material over the wearable length of the carbon. The wear rate of the brush and contact surface were reduced compared to the standard brush. For example the addition of a graphite insert would enhance film formation and reduce friction or a metal graphite insert would provide cleaning under contaminated conditions and help keep contact resistance low.



Jeff Koenitzer, Vice President Engineering, Helwig Carbon

HELWIG QUICK DISCONNECT TERMINAL AND MOUNT SYSTEM

The conventional method for the stationary electrical connection of carbon brushes is a terminal with slot or hole attached to a bolt. Although this is a reliable low resistance connection it can be tedious to change a large number of brushes. During the early 1960’s there was increasing demand for the ability to safely and



efficiently change brushes while the equipment was still operating. It was not, however, until Helwig Carbon introduced the Helwig Quick Disconnect Terminal and Mount System, that there was a successful product for the long term.



MULTI-SECTION BRUSHES

Throughout the 1900s there was improvement in performance, efficiency, and size of motors and generators. This progress caused extra stress on the carbon brushes and stimulated continuous grade and brush design development. In particular the desire for higher power per a given frame size led to an overall increase in the voltage rating on DC machines. Increased voltage caused higher bar to bar voltage differences, increased potential for circulating currents between bars, and more commutation stress.

Speer Carbon founded in 1899 in St. Marys, PA USA has been the source of raw material brush plate throughout the history of Helwig Carbon Products. Their carbon brush division developed the solution for satisfactory brush performance under these more demanding commutating conditions. The use of two independent carbon pieces in one brushholder was first done by Speer Carbon with later field testing by Helwig Carbon. This design increased the resistance between the entering and exiting edges of the contact face. This increased the resistance of the

short circuit path between commutator bars and allowed the brushes to commutate better than a solid single piece contact and kept carbon brush maintenance to a satisfactory level. The use of Multiflex and Triflex independent carbon sections was registered under U.S. Patent 2,181,076 to William Siebenmorgen and Speer Carbon on July 23, 1938.*



*Note Helwig Carbon Products, Inc. purchased the former Speer Carbon Brush Division in July 2009 and is owner of the referenced patents.

TAMPED CONNECTIONS



The demand for more power also led to machine designs with higher amps conducted by the brushes. This put higher heat stress on the area of highest resistance in a carbon brush, the connection of the wire to the carbon material. Various methods of attachment had been

used in the early years, however, by the 1940's the tamped connection had become the most popular choice. This method involved a drilled hole in the top of the carbon and the compacting of conductive powder around the wire with a special machine that included precise adjustment and special tooling. The copper powder most commonly used was reaching its limit on some applications where there were very high and widely varying amp loads. The resistance of the tamped connection would increase, the powder would meld

together, and there would be a failed connection with the wire pulling out from the carbon. The testing of silver plated copper powder at Speer Carbon was very successful in keeping a low resistance wire connection throughout the life of the brush. U.S. Patent 2,631,252 was granted to Speer Carbon in 1953 as recognition of the clear advantage of silver coated copper tamping powder. Even today Helwig Carbon is unique in use of this powder for a higher quality and more reliable long term service of carbon brushes.*

TAMPED CONNECTIONS FOR SEVERE DUTY APPLICATIONS

Higher amp loads on severe duty industrial and railway applications brought about further demands for an improved wire connection. Speer Carbon responded with the development of graphite tamping powder. The uniformity of thermal expansion with the carbon in the powder and the brush allowed the connection to remain low in resistance throughout the life of the brush under very demanding conditions. Once again Speer Carbon registered this development under U.S. Patents 3,510,710 in 1970 and 3,666,688 in 1972. For the life of the patent only Speer Carbon and Helwig Carbon provided the product advantage of a graphite tamped connection. All major carbon companies have since followed in the use of this development.*

WEAR INDICATOR

Maintenance personnel have always had a need for easy indication when worn brushes should be replaced. Many concepts have been attempted to address this need with modest success. Various marks on the carbon provide accurate information, however, most often the brush needs to be removed from the holder to see the wear mark. Wear bands on the shunt wires are difficult to view accurately with the inconsistent bending of wires. Embedded sensor wires can be connected to an external warning circuit. This method, however, provides warning at only one point in time and can be complex extra wiring if there are many such brushes in a set. Some small brush designs have incorporated lifting devices that interrupt the contact with the rotating surface and stop the machine. This saves the contact surface from damage, however, the shutdown of the motor is the only warning that brushes are too short.

In response to the need and the deficiencies of other methods the Helwig Carbon brushholder designers developed a wear indicator as part of the

constant force spring clip assembly. The indicator projects above the brushholder for continuous accurate viewing of the amount of brush wear length available. At the point when the red tape is even with the top of the spring clip the spring force will begin to decline, the brush wear rate will increase at an accelerating rate, and the brush should be changed. None of the other indicator methods can clearly show the amount of wear left while the machine is running.



CONTACT SPRING PRESSURE

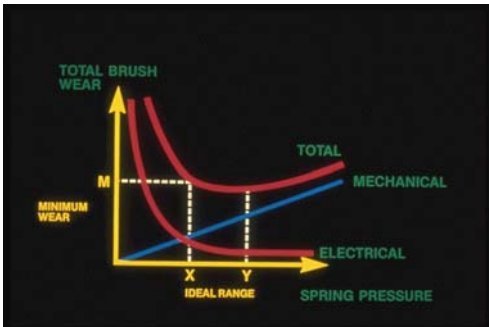

There has always been a fear of applying excess spring force on carbon brushes since that would increase the brush wear rate. On old adjustable spring force holders the instruction was to decrease spring force until there was visible arcing and then increase the force one notch. The recommended spring pressure had been 1.5 to 2.5 PSI depending on the application. The graph shows the relationship between mechanical, electrical,

and total wear in relation to spring reactions to the recommendation of pressure.

In the early 1980s Speer Carbon conducted lab tests to determine voltage drop and coefficient friction at various spring pressures. Helwig Carbon analyzed the test data in order to determine the ideal spring pressure range for minimal brush wear under typical operating condition for industrial machines. The results showed that 4.0 PSI or 280 g/cm² is the appropriate spring pressure for minimum brush and contact surface wear for typical operating conditions on industrial machines. A technical paper, “The Effect of Spring Pressure on Carbon Brush Wear Rate” was written and presented in 1983. The initial

spring pressures almost double those of existing standards, were primarily skepticism. However, the concept was understandable, believable, and of sufficient benefit that many tried the new recommended spring pressure during the following years. The results exceeded all expectations. When the spring pressure was increased to the new recommended level, the typical brush life improved by 50% or more and dramatically reduced the need for resurfacing of brush contact surfaces. Today almost all standard recommendations for spring pressure have been increased in reaction to this test and the subsequent improved field results.



TEFLON COATED HOLDERS



Helwig Carbon is pleased to announce a new coated brush holder for harsh industrial environments. This option is available on all types of brush holders. According to Christopher Eiteljorge, Electrical Engineer with Steel Dynamics,

“Prior to joining the department in 2010, our Pickle Line DC motors used GE brush boxes and Helwig Carbon Red Top brushes. At that time, it was commonplace to be changing brushes and brush boxes on some of our more problematic motors up to once every month due to the Hydrochloric Acid fumes experienced on a Pickle Line. Since implementing the Helwig Carbon special coated holders on these motors we have seen a significant decrease in frequency of brush and brush holder changes.

In mid-2010, our Tension Reel A motor consisted of standard GE uncoated holders with Helwig Carbon Red Top brushes while our Tension Reel B motor consisted of Helwig Carbon special coated brush holders with silver plated hardware and Helwig Carbon Red Top brushes. All of the brushes and holders were installed at the same time. Doing monthly inspections over the course of one year, every single GE brush holder had to be replaced before a single Helwig Carbon special coated holder was replaced. The special coating and silver plating provided enough resistance to the HCI atmosphere that the brushes could slide freely in their holders.

With the results that we have seen with the in-service testing described above, I plan on working with Bill Fleming from Horner Industrial Services, Inc. in Indianapolis, IN on a large order of Helwig Carbon special coated brush boxes with a goal of replacing the brush boxes in all of our problematic motors and stocking spares for each as well.”

HELWIG’S BANK OF TWO HOLDERS

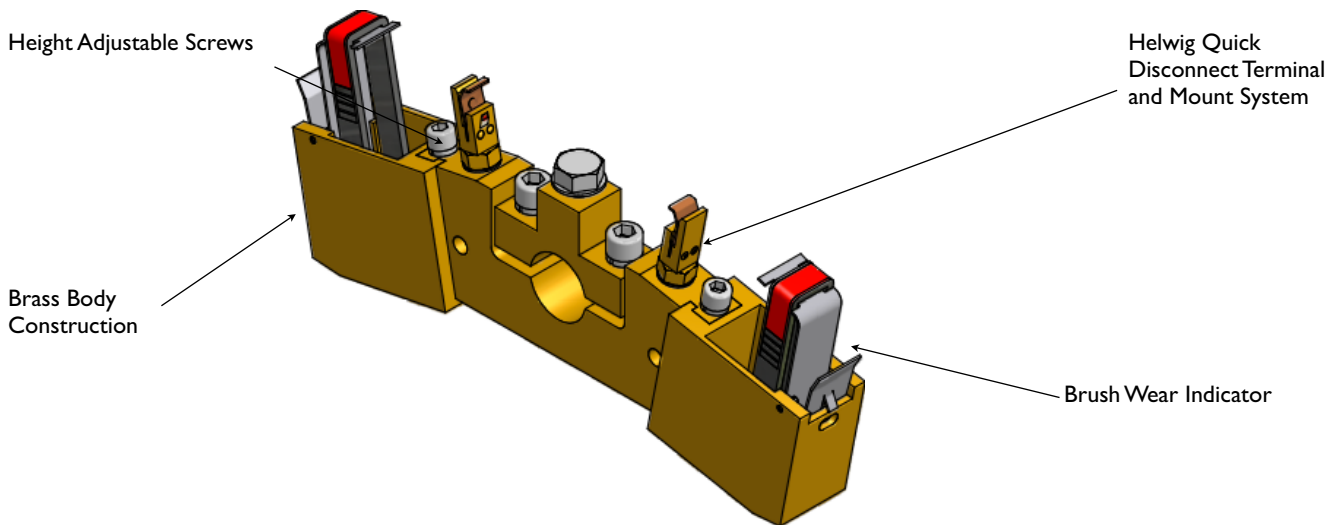

THE TRADITION CONTINUES

As one reflects back on the impact of the various developments it is clear today how each has had a significant impact on the progression of carbon brushes. Longer product life, better performance, and improved performance were the motives for each innovation and history has shown the successful outcome. Helwig Carbon Products, Inc. is proud to have participated in bringing this impressive list of innovations to successful completion and implementation. There is no doubt that the contributions of Helwig Carbon have prolonged the use of carbon brushes as a viable means of providing electrical power to moving surfaces.



POST-MOUNTED
ADJUSTABLE SLIP RING
HOLDERS



Adjustable to many different ring diameters and post locations

Helwig Carbon Products offers innovative designs with their adjustable slip ring brush holders. They replace the need for the single holder design.

The popular Post Mount Bank of Two can be made with adjustable boxes, or the offset adapter allows it to replace the bank of two design.

Holder Brush boxes come in a variety of sizes

Helwig offer 6 different standard brush box sizes with a variety of post diameters available. Simply supply the post diameter and brush size needed.

A variety of adapter post diameters are available. They are stocked in 0.750” to 1.375” with other sizes available upon request.



Save time and money

Let Helwig review your application for proper brush grade, brush size, and spring force.



They are usually able to suggest alternate brush sizes, grades, or number of brushes per set based on current density, duty cycle and speed, ultimately saving maintenance time and money.

VISIT HELWIG CARBON ON THE WEB



Helwig’s website makes shopping and finding product information easy.

For more in depth information on brush ID and installing carbon brushes and brush wear indicators or take a virtual plant tour by visiting them on YouTube at Helwig Carbon.



HELWIG CONTACT
INFORMATION
**Customer Service and Order
Entry**

PH: 800-962-4851

FX: 800-365-3113

Email:

carboncrew@helwigcarbon.com

**Tech Squad for Brush and
Holder Identification**

Email:

techsquad@helwigcarbon.com

Website

www.helwigcarbon.com

Contact

DANIEL PERKINS



PH: 253-853-7456

Email:

daniel.perkins@perkinpowerproducts.com

TRACY PERKINS



PH: 253-853-7456

Email:

tracy.perkins@perkinpowerproducts.com

PERKINS POWER
PRODUCTS, LLC

Visit us on the web:
perkinpowerproducts.com